

DATASHEET CATAMARAN

It is critical to fill in complete and accurate information for the safe transport of your yacht.

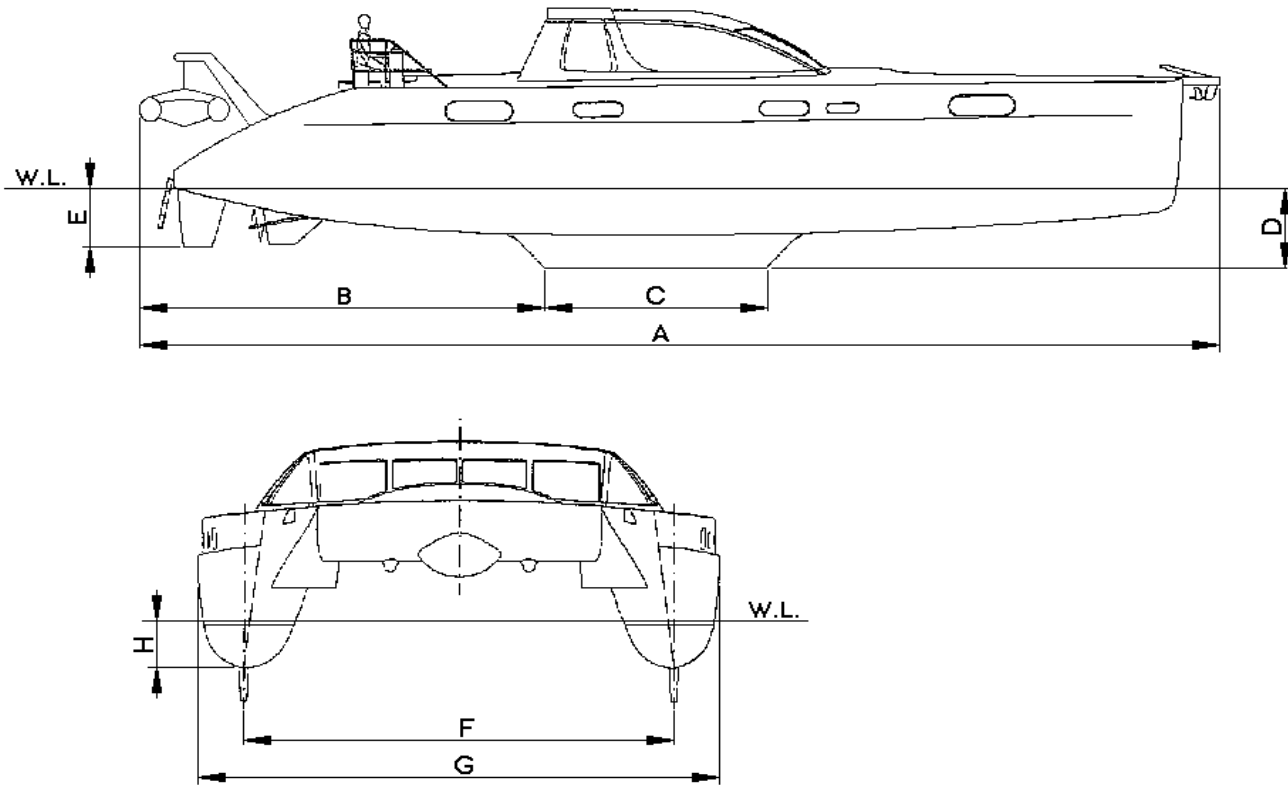

Name of yacht:	
Booking note / inquiry number:	
Voyage :	
Builder:	
Model, type and hull number:	
Weight (Displacement) of yacht in metric tons:	
Hull material:	
Catamaran Type? Sail Motor	If motor, max protrusion of rudder or props below keel.

Can the keel carry the weight of the yacht:	Yes	No
Is the keel retractable:	Yes	No

A	Length over all incl. davits, tender or other:	
B	Start of keel:	
C	Length of keel:	
D	Max. draft:	
E	Height rudder, measured from bottom rudder to waterline:	
F	Distance between centre lines two hulls:	
G	Beam max:	
H	Distance bottom hull to waterline:	

ADDITIONAL DATA LIFT ON -LIFT OFF

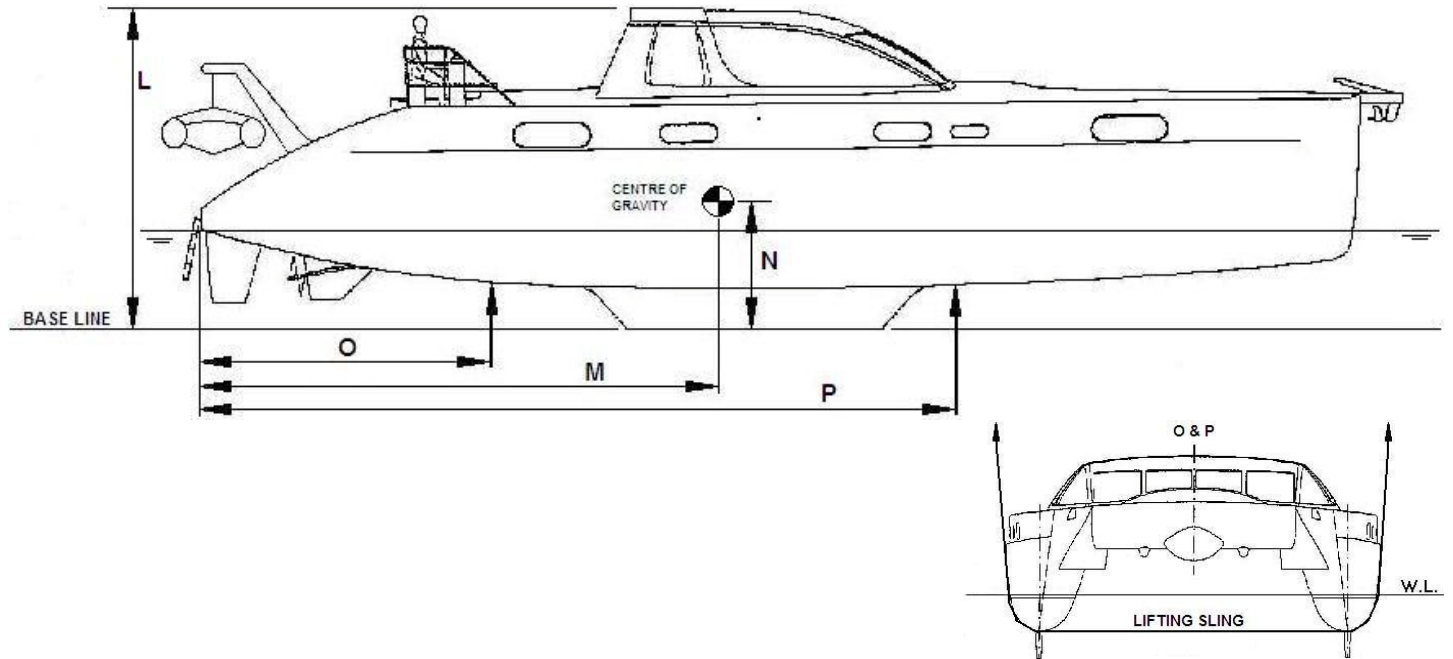

In addition to our standard datasheet, please fill out this form. If a drawing is available indicating the measurements mentioned on this form, please send us a copy.

Sail or Motor Catamaran?	Sail*	Motor
--------------------------	-------	-------

*Is it possible to remove mast(s)? YES NO

	Total height including antennas / scanners / masts, etc. measured from base line:	
L	Height from base line to top deckhouse:	
M	Longitudinal position of Centre of Gravity:	
N	Vertical position of Centre of Gravity:	
O	Aft lifting sling position measured from transom:	
P	Fwd lifting sling position measured from transom:	